

# 11 Angles and Ratios

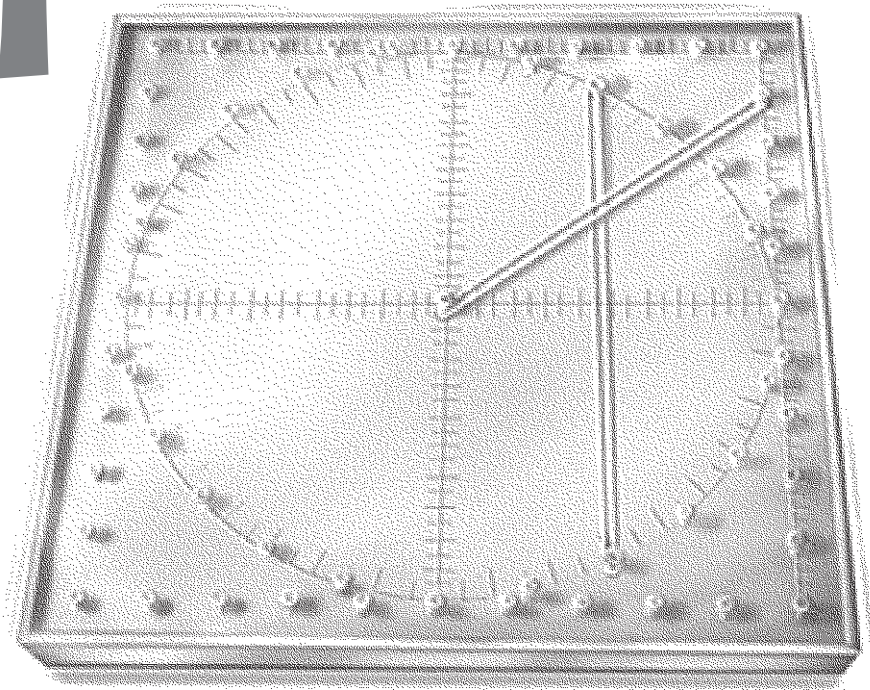

This section provides a new entry into trigonometry. You can use it as a preview or introduction to trig in grades 8–10 or as a complement to a traditional or electronic-based approach in grades 10–11. Of course, the section is far from offering a comprehensive coverage of trigonometry, but it does introduce the basics of right triangle trig, plus the unit circle, in a way that should be accessible to all students.

The essential tool is the 10-cm-radius circle geoboard, or paper versions of it (see p. 245). The design of the board includes:

- a built-in protractor;
- accurately marked  $x$ - and  $y$ -axes as well as tangent and cotangent lines;
- strategically placed pegs to support an introduction to right triangle and circle trigonometry.

To demonstrate uses of the CircleTrig geoboard on an overhead projector, make a transparency of the paper version.

The section starts with an introduction to the tangent ratio, which is more accessible than sine and cosine and is related to the already familiar concept of slope. The sine and cosine ratios follow. (At the Urban School,

we introduce the tangent ratio in the first semester of our Math 2 course and the sine and cosine in the second. This way students' energy can be focused on understanding the underlying concepts, rather than on trying to memorize which of the ratios is which.) Students build tables of those functions and their inverses with the help of the circle geoboard and then use the tables to solve "real world" problems. The names *tangent*, *sine*, and *cosine* are not used right away, mostly as a way to keep the focus on the geometric and mathematical content. Of course, these names need to be introduced sooner or later, and you will have to use your judgment about whether to do that earlier than is suggested here. If you are using these labs in conjunction with other trig lessons, you may not have the option of postponing the introduction of the names, given that students will recognize the ratios.

In any case, when you do introduce the names, you will need to address the students' question, "Why are we doing this when we can get the answer on the calculator?" The answer that has worked for me is, "You can use your calculator if you want, but for these first few labs, show me that you understand the geometric basis of these ideas." The calculator is the method of choice if you're looking for efficiency, but the geometric representation in the circle is a powerful mental image, which will help students understand and remember the meaning of the basic trig functions.

**See page 231 for teacher notes to this section.**

# LAB 11.1

## Angles and Slopes

Name(s) \_\_\_\_\_

■ **Equipment:** CircleTrig geoboard, CircleTrig geoboard sheet

The CircleTrig geoboard and the CircleTrig geoboard sheet include ruler and protractor markings.

1. Label the rulers on the sheet (not on the actual geoboard) in 1-cm increments.
2. Label the protractor markings on the sheet in  $15^\circ$  increments. Start at  $0^\circ$  on the positive  $x$ -axis, going counterclockwise. Include angles greater than  $180^\circ$ .
3. Repeat Problem 2, going clockwise. In this direction, the angles are considered negative, so this time around,  $345^\circ$  will be labeled  $-15^\circ$ .

Think of the line with equation  $y = mx$ , and of the angle  $\theta$  it makes with the positive  $x$ -axis ( $\theta$  is the Greek letter *theta*). Each slope  $m$  corresponds to a certain angle between  $-90^\circ$  and  $90^\circ$ .

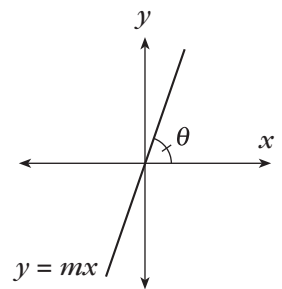

You can think about this relationship by making a right triangle on your CircleTrig geoboard like one of those shown below.

The legs give the rise and run for the slope of the hypotenuse.

You can read off the angle where the hypotenuse crosses the protractor to find the angle that corresponds to a given slope.

Note that even though both examples at right show positive slopes, you can use the CircleTrig geoboard to find the angles corresponding to negative slopes as well.

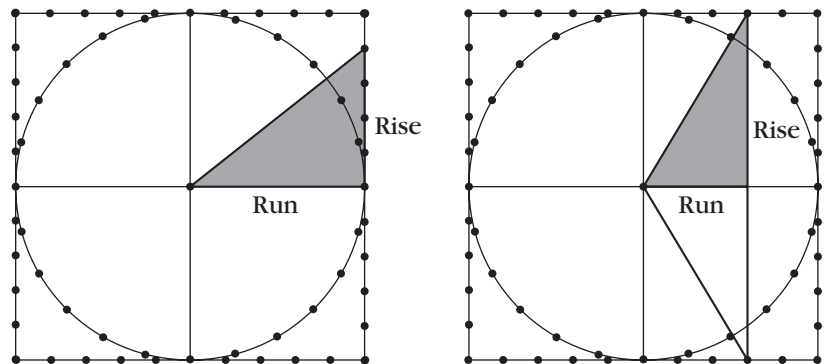

Two ways to find the angle for a given slope (Problem 4)

You can also find slopes that correspond to given angles.

Two examples of how to do this are shown at right.

In the first example, you can read rise off the  $y$ -axis and run off the  $x$ -axis.

In the second example, the rubber band is pulled around the  $30^\circ$  peg, past the right edge. You can read rise off the ruler on the right edge. (What would run be in that example?)

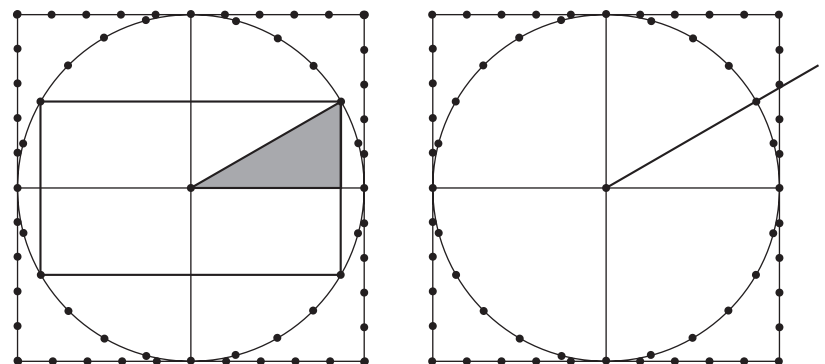

Two ways to find the slope for a given angle (Problem 5)

**LAB 11.1**

Name(s) \_\_\_\_\_

**Angles and Slopes (continued)**

4. Fill out the table below. Continue a pattern of going around the outer pegs of the geoboard to supply slopes where the table is blank. For angles, give answers between  $-90^\circ$  and  $90^\circ$ . (That is, make your slope triangles in the first and fourth quadrants.)

$m$	0	0.2	0.4	0.6	0.8	1	1.25	1.67				-5		
$\theta$												$90^\circ$		

5. Fill out the table below.

$\theta$	$0^\circ$	$15^\circ$	$30^\circ$	$45^\circ$	$60^\circ$	$75^\circ$	$90^\circ$	$105^\circ$	$120^\circ$	$135^\circ$	$150^\circ$	$165^\circ$	$180^\circ$
$m$													

**Discussion**

- A. What patterns do you notice when filling out the tables? What is the relationship between the slopes of complementary angles? For what angles is the slope positive? Negative? 0? For what angles is the slope between 0 and 1? Greater than 1?
- B. Why is there no slope for the angle of  $90^\circ$ ?
- C. Explain how you chose one or another of the four types of slope triangles to help you fill out the tables.
- D. Some of the slope triangles you used to fill out the tables are “famous right triangles.” Check that the angles and slopes you found are correct by comparing your answers with those you got in Lab 10.7.

# LAB 11.2

## Using Slope Angles

Name(s) \_\_\_\_\_

■ **Equipment:** The tables from Lab 11.1, CircleTrig geoboard, CircleTrig geoboard paper

1. How tall is the flagpole?

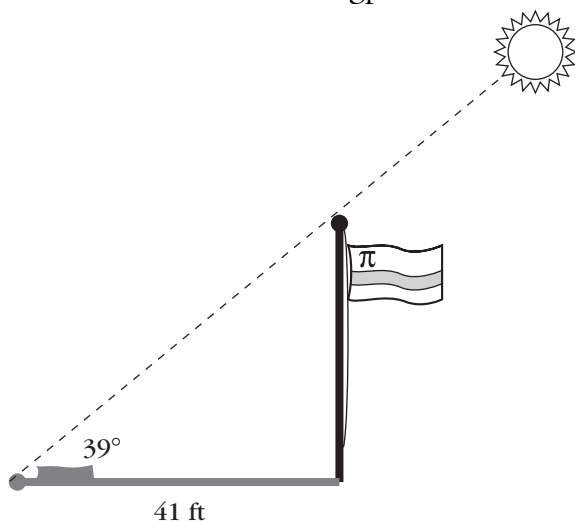

2. How far is the boat from the edge of the cliff?

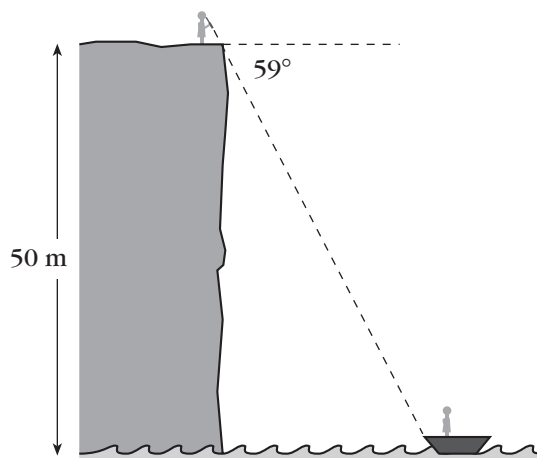

For the remaining problems, make your own sketches on a separate sheet of paper.

- Looking down at a boat from a 30-m-high lighthouse, an observer measures an angle of  $15^\circ$  below the horizontal.
  - Sketch this.
  - How far is the boat from the base of the lighthouse?
- A ski lift rises 200 meters for a run of 250 meters. What angle does it make with the horizontal?
- At a certain time of day, a 33-ft flagpole casts a 55-ft shadow. What is the angle made by the sun's rays with the horizontal?
- The banister of a straight staircase makes an angle of  $39^\circ$  with the horizontal. The stairs connect two floors that are 10 feet apart.
  - How much horizontal space does the staircase take?
  - If steps are 8 inches high, how wide are they?
- You stand on a cliff, looking down at a town in the distance. Using a map, you find that the town is 1.2 km away. The angle your line of vision makes with the horizontal is  $11^\circ$ . How high is the cliff?
- A right triangle has a  $15^\circ$  angle and a short leg of 18 units. How long is the long leg?
- A right triangle has a  $75^\circ$  angle and a short leg of 18 units. How long is the long leg?

## LAB 11.2

### Using Slope Angles (continued)

Name(s) \_\_\_\_\_

#### Discussion

- A. The problems in this lab have been rigged to use only angles and slopes that you included in the tables. The figure suggests a method for finding the slopes and angles in other cases by using a rubber band *between* pegs on the CircleTrig geoboard or a ruler on the paper geoboard. Explain the technique.
- B. Find the angles for slopes of 10, 25, 100. What happens as the slope gets bigger and bigger?

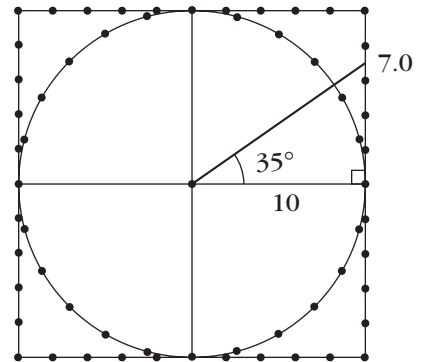

# LAB 11.3

## Solving Right Triangles

Name(s) \_\_\_\_\_

- **Equipment:** CircleTrig geoboard or CircleTrig geoboard paper

Right triangles are crucial in many parts of math, physics, and engineering.

The parts of a right triangle are (not counting the right angle):

- two legs;
- one hypotenuse;
- two acute angles.

You will soon know how to find all the parts given a minimum amount of information. Finding all the parts is called *solving* a triangle.

For each problem below, answer the question and work the example. Use the figure to keep track of what you know.

1. Given one acute angle, what other parts can you find?  
(Example: One acute angle is  $21^\circ$ .)

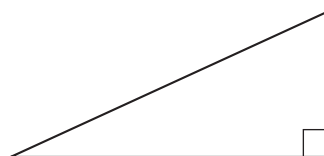

2. Given one side, what other parts can you find?  
(Example: One side is 3.)

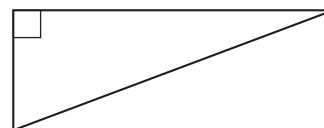

3. Given two legs, what other parts can you find?  
(Example: One leg is 4 and the other is 5.)

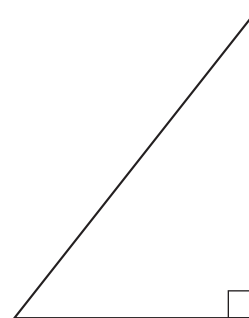

4. Given one leg and the hypotenuse, what other parts can you find? (Example: One leg is 6 and the hypotenuse is 7.)

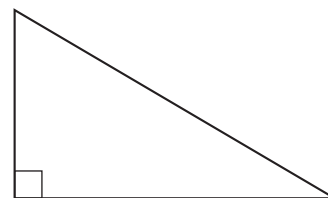

## LAB 11.3

### Solving Right Triangles (continued)

Name(s) \_\_\_\_\_

5. Given one leg and the acute angle adjacent to it, what other parts can you find? (Example: One leg is 8, and it is adjacent to a  $9^\circ$  angle.)

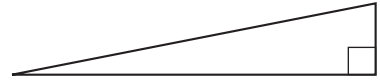

6. Given one leg and the opposite acute angle, what other parts can you find? (Example: One leg is 10, and the opposite angle is  $32^\circ$ .)

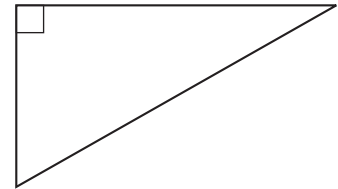

7. Given the hypotenuse and an acute angle, what other parts can you find? (Example: The hypotenuse is 4, and one angle is  $65^\circ$ . **Hint:** Create your own right triangle with angle  $65^\circ$  and scale it.)

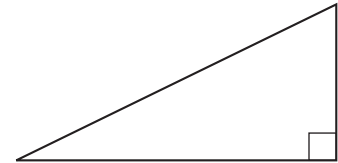

### Discussion

- A. What is the minimum amount of information necessary to completely solve a right triangle?
- B. When you know only one leg, is there a way to know if it is the long leg or the short leg (or whether the legs are the same length)?
- C. Problem 7 is much more difficult than the others. Why?



# LAB 11.4

## Ratios Involving the Hypotenuse

Name(s) \_\_\_\_\_

■ **Equipment:** CircleTrig geoboard, CircleTrig geoboard paper

In Labs 11.1 and 11.2, we were working with three numbers: the two legs of a right triangle (which we thought of as rise and run) and an angle. Given any two of those, it was possible to find the third. In some right triangle situations, however, the three numbers you have to work with could be the hypotenuse, one leg, and an angle.

To address such problems, we will use two ratios involving the hypotenuse:

$$\frac{\text{adjacent leg}}{\text{hypotenuse}} \quad \text{and} \quad \frac{\text{opposite leg}}{\text{hypotenuse}}$$

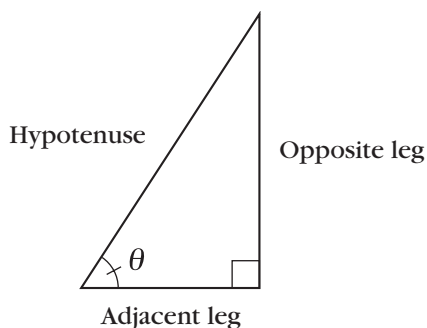

To find those ratios, use your CircleTrig geoboard. To find lengths of adjacent and opposite legs, recall how you found slopes for given angles in Lab 11.1. See the figure at right. Using this method, the length of the hypotenuse will always be the same (what is it?), which makes it easy to write the ratios without using a calculator. Enter your results in the table below. Since you can find lengths to the nearest 0.1 cm, express your ratios to the nearest 0.01 unit.

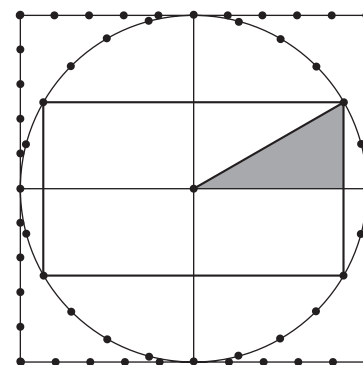

$\theta$	opp/hyp	adj/hyp
$0^\circ$		
$15^\circ$		
$30^\circ$		
$45^\circ$		
$60^\circ$		
$75^\circ$		
$90^\circ$		

# LAB 11.4

Name(s) \_\_\_\_\_

## Ratios Involving the Hypotenuse (continued)

The figure at right shows one way to find an angle given an opp/hyp ratio of 0.4. Stretch a rubber band to connect two 4-cm pegs. Read off the angle where the rubber band crosses the protractor markings. (Can you see why the opp/hyp ratio is 0.4 in this example?) You can use a similar method to find angles for given adj/hyp ratios. Enter your results in the tables below.

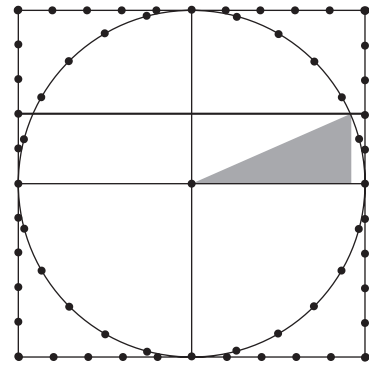

opp/hyp	$\theta$
0	
0.2	
0.4	
0.6	
0.8	
1	

adj/hyp	$\theta$
0	
0.2	
0.4	
0.6	
0.8	
1	

### Discussion

- When filling out the tables, look for patterns. What is the relationship between the ratios for complementary angles? For what angles do we have ratios of 0? 1?
- Some of the triangles you used to fill out the tables are “famous right triangles.” Check that the angles and ratios you found are correct by comparing your answers with those you got in Lab 10.7.
- Can the  $\frac{\text{opp}}{\text{hyp}}$  ratio, or the  $\frac{\text{adj}}{\text{hyp}}$  ratio, be greater than 1? Explain.

# LAB 11.5

## Using the Hypotenuse Ratios

Name(s) \_\_\_\_\_

■ **Equipment:** CircleTrig geoboard

**Example:** Find the area of a triangle with sides of 5 cm and 7 cm and an angle of  $15^\circ$  between those two sides.

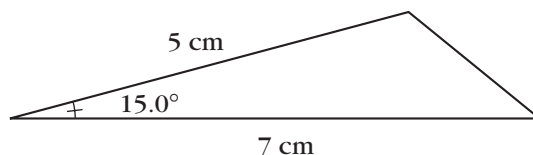

If we use the 7-cm side as the base, we need a height to calculate the area.

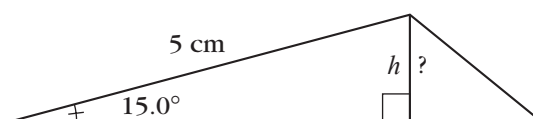

Using the table we made in the previous lab, we see that for a  $15^\circ$  angle the ratio  $\text{opp}/\text{hyp} = 0.26$ .

So we have  $\frac{h}{5} = 0.26$ .

1. What are the height and area of the triangle described above?

Solve the following problems by a similar method. Always start by drawing a figure.

2. What is the area of a triangle with sides of 4 cm and 6 cm and a  $24^\circ$  angle between those sides?
3. A 12-ft ladder is propped up against a wall. This ladder is safest if it is at a  $75^\circ$  angle from the horizontal. How far should the base of the ladder be from the wall?
4. What are the acute angles of a 3, 4, 5 triangle?
5. What is the acute angle of a parallelogram with sides of 3 cm and 8 cm and area of  $14.4 \text{ cm}^2$ ?

## LAB 11.5

Name(s) \_\_\_\_\_

### Using the Hypotenuse Ratios (continued)

6. A flagpole is held up by wires. You measure the distance from where one of the wires is attached to the ground to the foot of the pole and get 12 m. You measure the angle the wire makes with the horizontal and get  $78^\circ$ . How long are the wires?

#### Discussion

- A. Using the CircleTrig geoboard or the paper CircleTrig geoboard, how would you find the angles and ratios that are between the ones in the table you made in Lab 11.4? The figure shows an example for  $35^\circ$ .

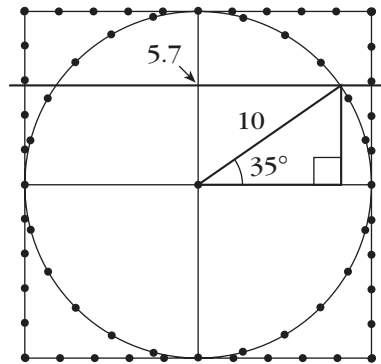

# Trigonometry Reference Sheet

The part of mathematics that studies ratios and angles is called *trigonometry*. Each of the ratios we have used in the past few labs has a name and notation, as shown below.

To get the ratio if you know the angle  $\theta$ , use:

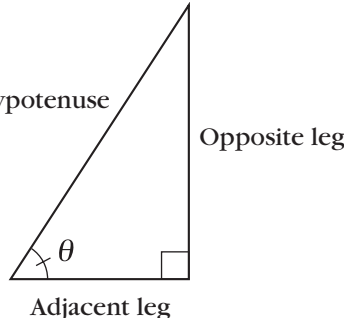
$$\frac{\text{opp}}{\text{hyp}} = \sin \theta \text{ (read "sine } \theta \text{")}$$
$$\frac{\text{adj}}{\text{hyp}} = \cos \theta \text{ (read "cosine } \theta \text{")}$$
$$\text{slope} = \frac{\text{rise}}{\text{run}} = \frac{\text{opp}}{\text{adj}} = \tan \theta \text{ (read "tangent } \theta \text{")}$$

To get the angle if you know the ratio  $R$ :

If  $R = \frac{\text{opp}}{\text{hyp}}$ , use  $\theta = \arcsin R$  or  $\theta = \sin^{-1}(R)$ .

If  $R = \frac{\text{adj}}{\text{hyp}}$ , use  $\theta = \arccos R$  or  $\theta = \cos^{-1}(R)$ .

If  $R = \frac{\text{opp}}{\text{adj}}$ , use  $\theta = \arctan R$  or  $\theta = \tan^{-1}(R)$ .

As you may suspect, engineers and physicists do not use geoboards to solve problems of the type we looked at in Lab 11.5. In the old days, they used tables, not unlike the ones we constructed but much more detailed. Later, they also used slide rules. Nowadays, they use calculators and computers. Scientific calculators have been programmed to give you the ratios, given the angles, or the angles, given the ratios. All you need to know are the official names of the three ratios we have been working with. To remember them, you can use one of the following mnemonics:

*soh-cah-toa*  
*soppy, cadjy, toad*

# LAB 11.6

## The Unit Circle

Name(s) \_\_\_\_\_

- Equipment:** CircleTrig geoboard or CircleTrig geoboard paper, Trigonometry Reference Sheet

At right is a figure that shows a *unit circle*, in other words, a circle with radius 1. Angles on the unit circle are measured from the  $x$ -axis, with counterclockwise as the positive direction. Angles can be any positive or negative number.

- Explain why on the unit circle all three trig ratios can be thought of as ratios over 1. Use an example in the first quadrant, such as the one in the figure at right.

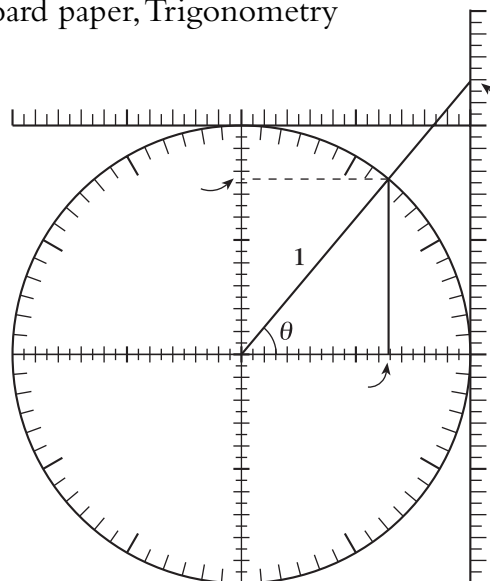

- Mark on the figure above where the sine, cosine, and tangent of the angle  $\theta$  can be read on the axes with no need to divide.

The cosine and sine of an angle can be defined respectively as the  $x$ - and  $y$ -coordinate of the corresponding point on the unit circle. This definition works for any angle, not just the acute angles found in a right triangle.

As for the tangent, you already know how to find the tangent for any angle: It is the slope of the corresponding line (see Lab 11.1: Angles and Slopes).

The *tangent* ratio is so named because it is related to a line tangent to the unit circle: specifically, the vertical line that passes through the point  $(1, 0)$ . If you extend the side of an angle (in either direction) so that it crosses the tangent line, the tangent of the angle can be defined as the  $y$ -coordinate of the point where the angle line and the tangent line cross. Note that the angle line, when extended through the origin, makes two angles with the positive  $x$ -axis—one positive and one negative. These two angles have the same tangent since they both define the same line.

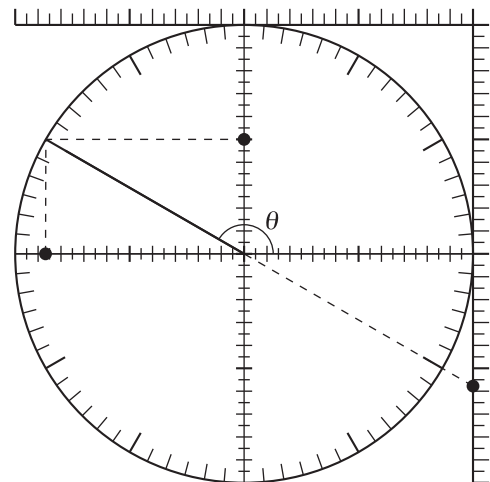

- Mark on the figure above where the sine, cosine, and tangent of the obtuse angle  $\theta$  can be read on the axes with no need to divide.

**LAB 11.6**

Name(s) \_\_\_\_\_

**The Unit Circle (continued)**

4. Show  $15^\circ$  and  $165^\circ$  angles on a unit circle. How are their sines related? Their cosines? Their tangents? Explain, with the help of a sketch.
5. Repeat the previous problem with  $15^\circ$  and  $345^\circ$ .
6. Repeat with  $15^\circ$  and  $195^\circ$ .
7. Repeat with  $15^\circ$  and  $75^\circ$ .
8. Study the figures on the previous page, and find the value of  $\sin^2 \theta + \cos^2 \theta$  (that is, the square of  $\sin \theta$  plus the square of  $\cos \theta$ ). Explain how you got the answer.

**Discussion**

- A. Refer to the figure at the beginning of the lab. Explain why you get the same ratios whether you use the smaller or the larger triangle in the figure. For each trig ratio, which triangle is more convenient?
- B. Use the smaller triangle to prove that  $\tan = \frac{\sin}{\cos}$ .
- C. For a large acute angle, such as the  $75^\circ$  angle in Problem 7, the tangent can no longer be read on the axis at the right of the unit circle, as its value would lie somewhere off the page. However, the axis that runs along the top of the unit circle is useful in such cases. How is the number you read off the top axis related to the tangent of the angle?
- D. Two angles  $\alpha$  and  $\beta$  (alpha and beta) add up to  $180^\circ$ . Draw a unit circle sketch that shows these angles, and explain how their trig ratios are related.
- E. Repeat Question D with two angles  $\alpha$  and  $\beta$  that add up to  $90^\circ$ .
- F. Repeat Question D with two angles  $\alpha$  and  $\beta$  whose difference is  $180^\circ$ .
- G. Repeat Question D with two angles  $\alpha$  and  $\beta$  that add up to  $360^\circ$ .
- H. Repeat Question D with two angles  $\alpha$  and  $\beta$  that are each other's opposite.
- I. Explain why the answer to Problem 7 is called the Pythagorean identity.

# LAB 11.7

Name(s) \_\_\_\_\_

## Perimeters and Areas on the CircleTrig™ Geoboard

- **Equipment:** CircleTrig geoboard or CircleTrig geoboard paper, Trigonometry Reference Sheet

Find the perimeter and area of each figure, assuming the circle has a radius of 10 cm.

1. a.

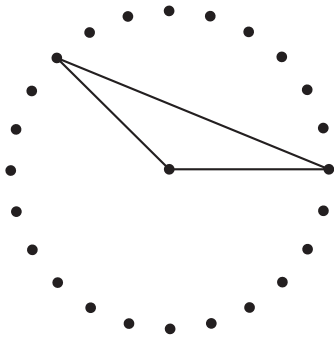

b.

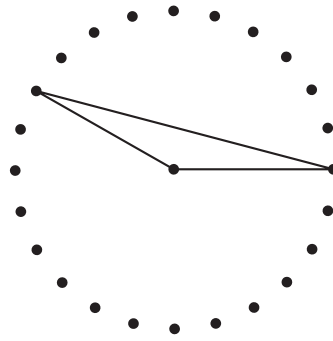

c.

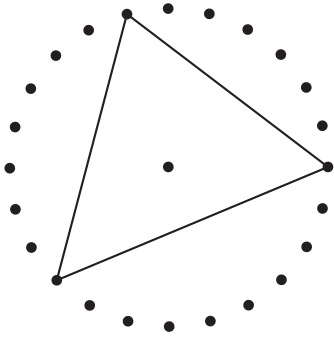

2. a.

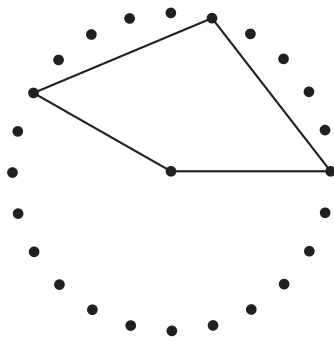

b.

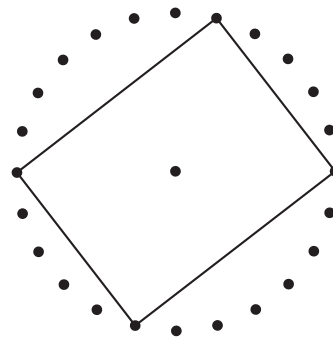

c.

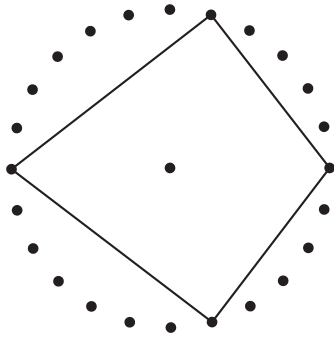



**LAB 11.7**

Name(s) \_\_\_\_\_

**Perimeters and Areas on the CircleTrig™ Geoboard (continued)**

3. Find the perimeter and area for the following regular polygons, inscribed in a circle with a radius of 10 cm.
  - a. Equilateral triangle
  - b. Square
  - c. Hexagon
  - d. Octagon
  - e. Dodecagon
  - f. 24-gon

**Discussion**

- A. The key to all the calculations in this lab is understanding how to find the base and height of an isosceles triangle the legs of which are 10-cm radii. Draw a figure for this situation, and assume a vertex angle of  $2\theta$ . What are the formulas for the base and the height? What are the formulas for the perimeter and area of the triangle?
- B. If you place a rubber band around the entire circle of the CircleTrig geoboard, you get a regular 24-gon. How close is it to the actual circle in perimeter and area?

# LAB 11.8

Name(s) \_\_\_\_\_

## " $\pi$ " for Regular Polygons

You probably know these formulas for a circle of radius  $r$ . ( $P$  is the perimeter, and  $A$  is the area.)

$$P = 2\pi r \quad A = \pi r^2$$

It follows from these formulas that  $\pi = \frac{P}{2r} = \frac{A}{r^2}$ .

For the purposes of this lesson, we will define the "radius" of a regular polygon to be the radius of the circle in which the polygon would be inscribed (in other words, the distance from the center of the polygon to a vertex). Furthermore, we will define  $\pi_p$  and  $\pi_A$  for a regular polygon as follows:

$$\pi_p = \frac{P}{2r} \quad \text{and} \quad \pi_A = \frac{A}{r^2}$$

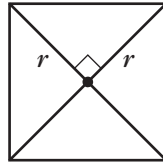

- For example, consider a square of "radius"  $r$  (see the figure above).
  - What is the perimeter?
  - What is  $\pi_p$ ?
  - What is the area?
  - What is  $\pi_A$ ?
- Think of pattern blocks. What is  $\pi_p$  for a hexagon?
- Use the figure below to find  $\pi_A$  for a dodecagon. **Hint:** Finding the area of the squares bounded by dotted lines should help.

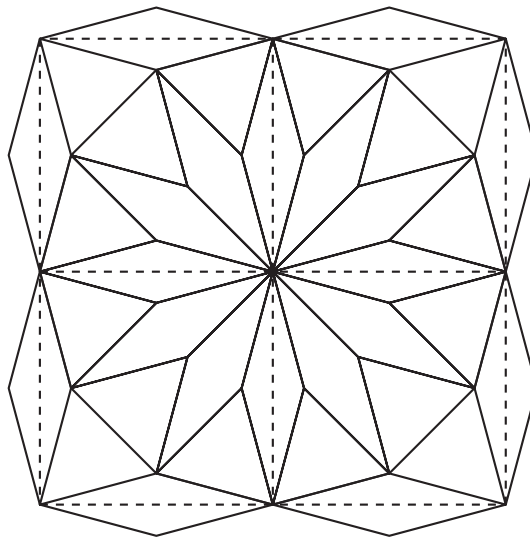

**LAB 11.8**

Name(s) \_\_\_\_\_

**" $\pi$ " for Regular Polygons (continued)**

4. In general, you will need trigonometry to calculate  $\pi_p$  and  $\pi_A$ . Do it for a regular pentagon. **Hint:** It is easiest to assume a "radius" of 1; in other words, assume the pentagon is inscribed in a unit circle. Be sure to use a calculator!
5. Fill out the table below. Here,  $n$  is the number of sides of the polygon. **Hint:** Start by mapping out a general strategy. Use sketches, and collaborate with your neighbors. You may want to keep track of your intermediate results in a table. Use any legitimate shortcut you can think of.

$n$	$\pi_p$	$\pi_A$
3		
4		
5		
6		
8		
9		
10		
12		
16		
18		
20		
24		

**Discussion**

- A. What patterns do you notice in the table?
- B. Write a formula for  $\pi_p$  and for  $\pi_A$ , as a function of  $n$ .
- C. What happens for very large values of  $n$ ?
- D. Of course, these values of  $\pi$  for polygons, while interesting, are not very useful. Why is the real value of  $\pi$  (for circles) more significant?

